

Installation and Operating Instructions

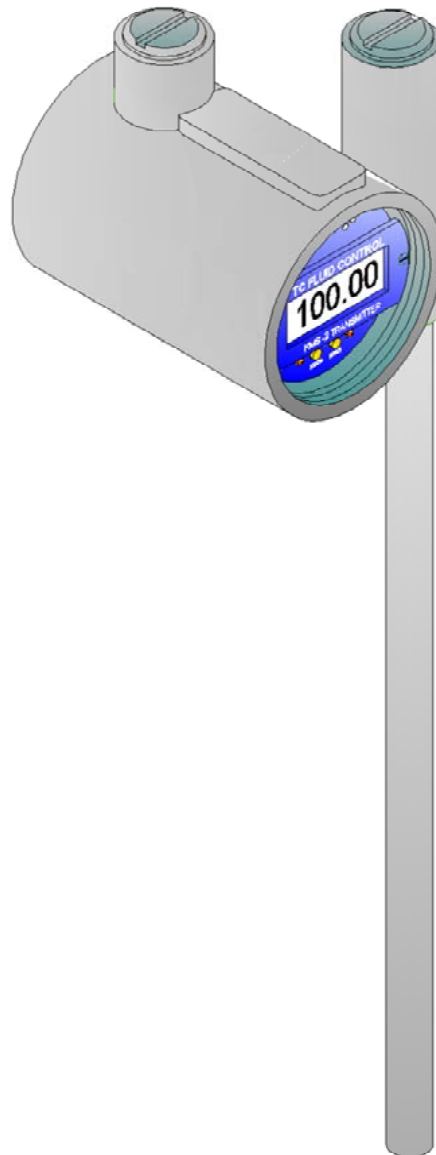

KMS-2 Exia Magnetostrictive Level Transmitter

Revision G 11/04/2022



Smart in sensing



KMS-2/Exia Transmitter

Installation and Operating Manual



Contents

| | |
|--|----|
| Symbols Used | 1 |
| Safety information | 1 |
| Introduction | 2 |
| Outputs | 2 |
| Installation General | 4 |
| Magnetic Level Gauge Applications | 4 |
| Immersion or in tank installation | 4 |
| Electrical Connections..... | 7 |
| Cable Selection | 7 |
| Adjustment and Configuration: | 8 |
| Configuration switches | 9 |
| Transmitter Front Panel Settings Flowchart | 10 |
| Certification | 11 |
| Fault analysis Sheet | 12 |
| Maintenance..... | 12 |
| Technical Data | 13 |

Symbols Used

The following symbols are used in these operating instructions:



Warning: If ignored injury or damage to property can occur.
Danger: If ignored serious injury or damage to property can occur.
Caution: Failing to comply with these instructions can lead to malfunction of or damage to the Level Transmitter.



Ex Applications

Instructions which must be complied with when the unit is used in potentially explosive environments and to meet the requirements of the EU/UK type examination certificate.



Information

Facts and information concerning proper operation of the KMS-2 Level Transmitters



Instructions for electrical installation

Information on proper electrical installation.



Safety information

Read these instructions before installation and putting into operation.

Installation commissioning and maintenance should only be carried out by suitably qualified personnel in conjunction with these instructions.

Comply with the relevant safety regulations when using the equipment.

The transmitter must not be modified as this will invalidate the warranty and or the product certification.

Measures must be taken to prevent risks to persons and property in the event of a defect.

Do not operate the Level Transmitters in the immediate vicinity of strong electromagnetic fields (minimum distance: 1 m) as this may give rise to incorrect readings.

Comply with the maximum current and voltage ratings as stated in the technical data section. For intrinsically safe applications installation of this unit must be in compliance with the applicable National requirements i.e. EN60079-14.

Introduction

A 4-20mA loop powered transmitter for measuring the level of liquid in a vessel either directly (immersion application) with an annular float, or indirectly by mounting on a magnetic level gauge. The Exia intrinsically safe version can be used in all hazardous area zones when connected through an approved isolation barrier.

The transmitter consists of a stainless steel tube, containing the Magnetostrictive measuring element, and an stainless housing containing the electronic circuit boards.

The unit operates by sending an electrical pulse down the sensing element; the resulting magnetic field reacts with the field from the magnetic float to produce a return signal. The time taken for the return signal to be detected enables a level measurement to be made since the precise velocity of the return signal along the sensing element is known.

Outputs

LCD Indicator: When fitted the display provides local indication dependent on the display mode as shown in table 1

| Mode | Function | Display Mode* ¹ | | |
|---|---------------------------------|----------------------------|---------------------|--|
| | | % Range | mA | PV (mm) |
| NORMAL | Measuring | 0.00/100.00 | 4.00-20.00 | Actual distance in mm from reference point |
| Fixed Output | Zero | 0.00 | 4.00 | Distance to Zero point |
| | Span | 100.00 | 20.00 | Distance to Span point |
| CALIBRATION | Start | CAL | 12.00 | CAL |
| | Zero set | CAL | 12.00 | CAL |
| | Span set | CAL | 12.00 | CAL |
| Fault signalling current setting | Downscale Set | AL.Lo* ² | 3.58* ² | AL.Lo* ² |
| | Upscale Set | AL.hi* ² | 22.00* ² | AL.hi* ² |
| Alarm | Low Level * ³ | ERR.L * ³ | 3.8* ³ | ERR.L * ³ |
| | Downscale * ⁴ | AL.LO | 3.58 | AL.LO |
| | Upscale * ⁴ | AL.HI | 22.00 | AL.HI |

Table 1
LCD indication

*¹ The standard display mode is % range, alternate modes available on request

*² Analogue output remains at last measurement value during setting (Rev 5 Onwards)

*³ When enabled by front panel switch, else will remain at 4mA until float no longer sensed.

*⁴ Alarm action, set as required (Default upscale).

Analogue Output: The process variable and error status are transmitted over the current loop with values as shown in table 2.

LED's: Provide local indication during calibration when the optional LCD is not fitted.

| Mode | Function | Outputs | | |
|---|------------------|----------|----------|----------|
| | | ANALOGUE | Zero LED | Span LED |
| NORMAL | Measuring | 4-20mA | Off | Off |
| Fixed Output | Zero | 4mA | On | Off |
| | Span | 20mA | Off | On |
| Fault Signalling Current Setting | Downscale | 4-20mA | Flash | Off |
| | Upscale | | Off | Flash |
| CALIBRATION | Start | 12mA | Flash | Flash |
| | Zero set | 12mA | On | Off |
| | Span set | 12mA | Off | On |
| Alarm | Low level | 3.8mA | Off | Off |
| | Downscale | 3.58mA | Off | Off |
| | Upscale | 22mA | Off | Off |

Table 2
Instrument output status indication



The Low Level alarm must be enabled as shown in the configuration section. When set the output signal will change to 3.8mA if the float drops more than 13mm below Zero point.



Installation General

Magnetic Level Gauge Applications

The unit should be fitted to the level gauge with reference to Fig1 using the mounting clips and insulation (if required) supplied. The unit should be positioned such that the XXXX marks around the circumference align with the upper and lower vessel connection points.

Ensure that the sensing tube is not distorted or strained during installation

The fixing clips should be spaced evenly along the length of the tube with a maximum centre distance 1000mm



If it is required to remove the transmitter for maintenance work ensure that any insulation is correctly fitted during reassembly to ensure operating temperatures are maintained within the range specified on the EU/UK type approval certificate.

Immersion or in tank installation

The transmitter should be fitted to the tank with reference to Fig.2. The distance between the tank connection and electronic housing will vary dependent on temperature and for a weld on connection be factory set.



Caution

When using an adjustable sealing gland ensure that the maximum ambient temperature for the electronic housing is not exceeded. (See technical data section).

Dependent on the length of the sensor tube an anchor point may be required at the bottom of the tank.



Where the transmitter is supplied with an adjustable gland care must be taken to ensure that the electronic housing temperature is maintained within that specified on the EU/UK type examination certificate. Please consult the sales office

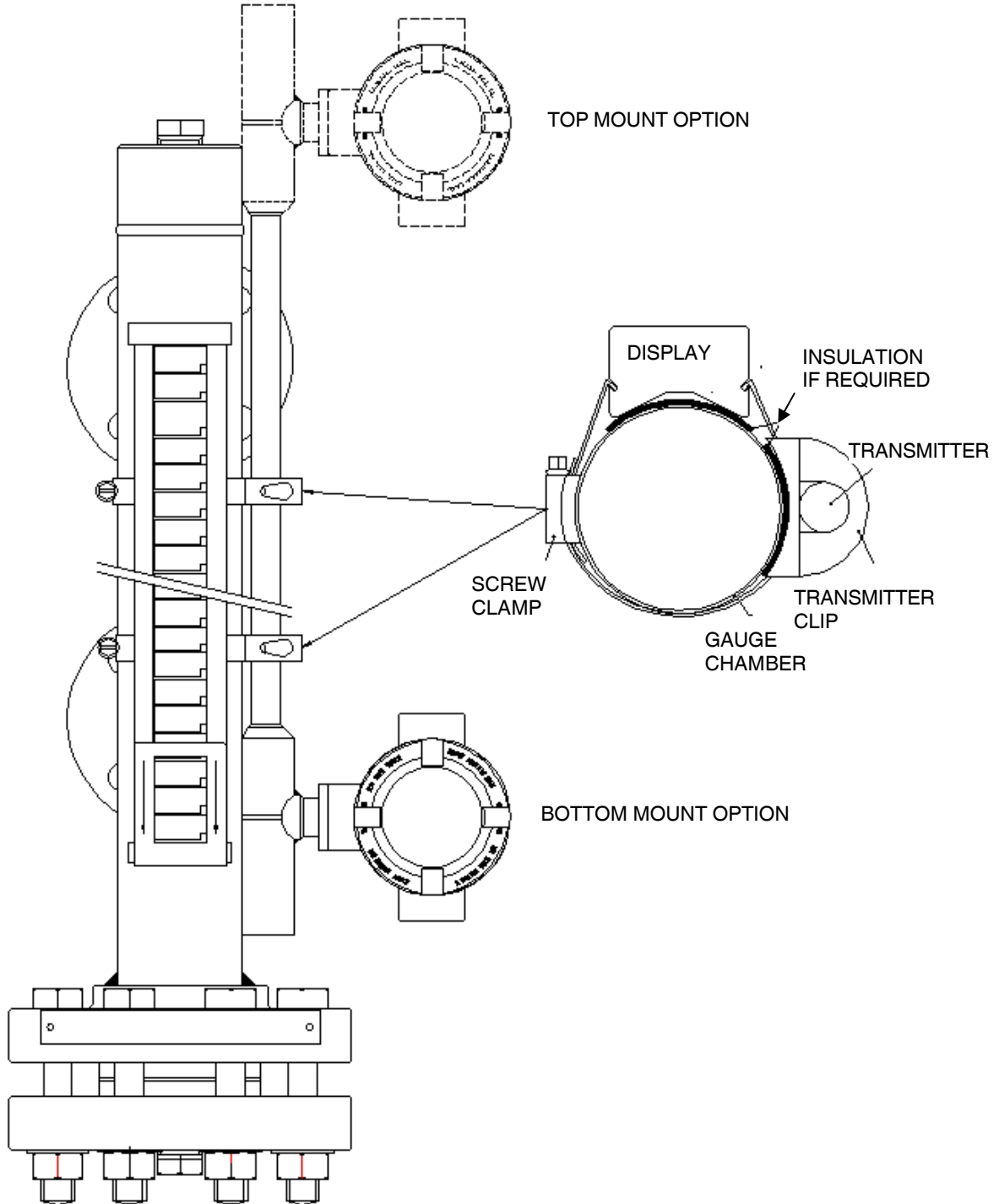

Fig 1
 Typical Installation When Fitted to Magnetic Level Gauge

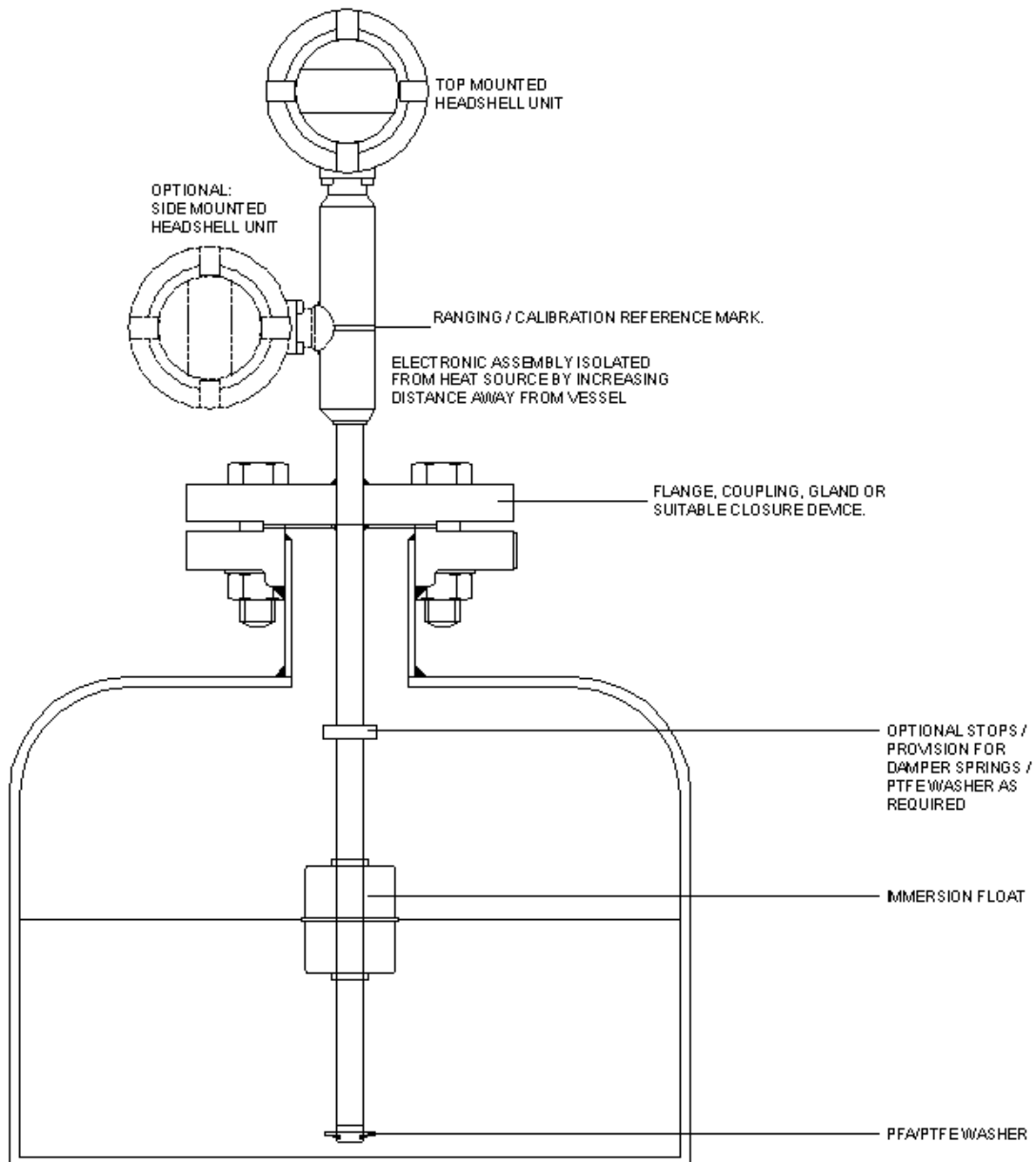
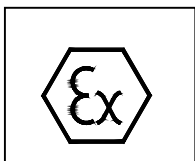

Fig 2
Immersion Application



Ensure that the PFA/PTFE washer is correctly fitted to prevent the risk of sparking if the float was to hit the stop.

Ensure that the electronic assembly is maintained within the certified ambient temperature range consult sales office to determine correct offset.

Electrical Connections

Unscrew the lid to gain access to the rear terminal enclosure; the terminal block can then be removed to facilitate connections.

Select the correct cable entry point dependent on the orientation of the sensor. The connection cable should be bought in through an M20 gland suitable to maintain the required IP rating, and then connected to the + and – terminals.

To prevent the risk of moisture ingress ensures that the connection cable is led downward in front of the cable gland

Cable Selection

The connection cable should be a twisted pair type suitable for the expected ambient conditions. When a screened cable is used, the screen should be connected to the internal earth connection provided.

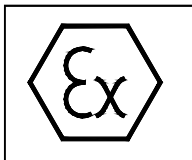

Hazardous area Installation

The installation of this unit must be in compliance with the applicable national requirements i.e. EN60079-14.

Intrinsically Safe Circuits

The connection cable shall be identified to prevent confusion with non-intrinsically safe circuits where a colour code is used it should be light blue.

The total inductance and capacitance of the cable shall not exceed the values stated on the intrinsically safe control device for the required gas group.

The connection cable should be bought in through the M20 cable entry via a suitable gland as necessary to maintain the required IP rating (minimum IP54).

When refitting the lid ensure that the sealing gasket is correctly fitted into the lid recess.

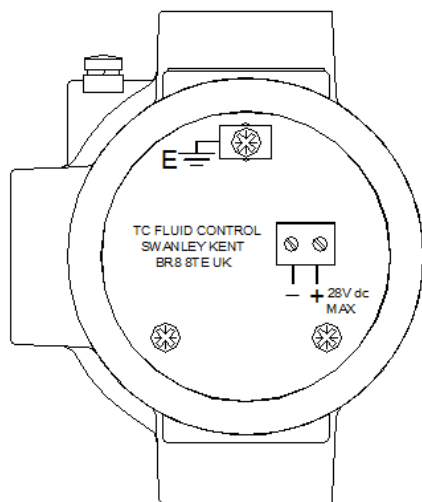

Fig 3 Cable entry via M20 Gland

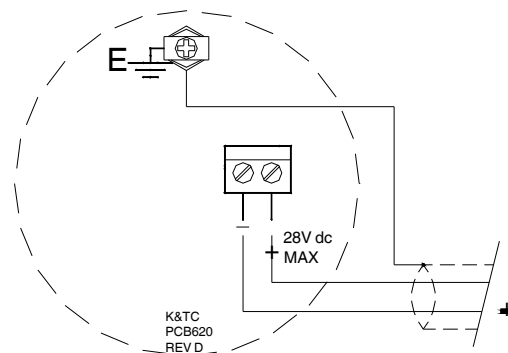

Fig 4 Connection Details

Adjustment and Configuration: (See also Flowchart Page 10)

The unit is normally set at the factory to the required specification:

- Range adjustment and output inversion (To customer requirements)
- Low Level Alarm Select (off)
- Fault Current Output (22mA)

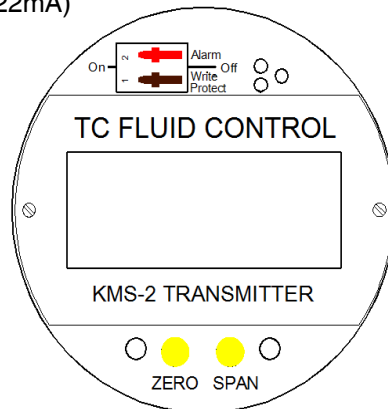

Fig 5
Internal layout of case showing
Local Display and calibration switches

Range Adjustment

The measuring range of the unit is set at the factory.

If the default range is unsuitable or adjustment is required the following procedure should be followed. With reference to Fig. 5

1. Set the float to the minimum level
2. Press the 'Span' and 'Zero' buttons until both LED,s flash alternatively (output 12mA)
3. Release buttons
4. Press the 'Zero' button until the 'Zero' LED stays on
5. Wait until the 'Zero' LED extinguishes. (output 4mA)
6. Set the float to the maximum level.
7. Press the 'Span' and 'Zero' buttons until both LED,s flash alternatively (output 12mA)
8. Release buttons
9. Press the 'Span' button until the 'Span' LED stays on
10. Wait until the 'Span' LED extinguishes. (output 20mA)



If the optional LCD is fitted the display will read 'CAL' during the setting process. The measuring range can be set within the factory limits with a maximum turndown of 50%. If an error is detected during the ranging process the unit will default to the previously saved values the relevant LED will flash if ranging failed.

Inverse output

The output is normally set so that the 20mA point is at the Head shell end. If it is required to mount the head shell at the bottom the output can be inverted by following procedure.

1. Move the float to approximately 50% of range
2. Set the 'Zero' level as 2-5 above
3. Move the float to the required maximum level
4. Set the 'Span level as 7-9 above,
5. Move the float to the required minimum level zero level.
6. Set the 'Zero level as 2-5 above.

The unit will then automatically invert the output.



Caution

The float failure and write protect switches should be set to the 'OFF' position before adjustment to the ranging are made, and reinstated as necessary afterwards.

It is important that the float is kept stationary for approximately 10 seconds before and after operation of the calibration buttons to ensure that the output signal has stabilised to the correct value.

Fault signalling Current (Rev 5 Onwards)

When the magnetic field from the float is not detected the default output level is set Upscale (22mA). To change to Downscale (3.5mA)

1. Press and release the span & zero buttons
2. Setting is indicated on LCD display and or respective LED
3. To change, press and release respective button
 - a) Zero button (Downscale 3.5mA)*
 - b) Span button (Upscale 22mA)*
4. Relevant LED will flash to signify save to memory
5. When complete display will revert to normal measurement mode.

*If change not required wait 20 Seconds unit will return to "Measurement Mode"

Low level alarm

The Low Level alarm output signal will change the output to 3.8mA if the float drops more than 13mm below zero point. When off the output will remain at 4mA below the zero point until the return signal is lost i.e. the sensor is no longer sensing the magnetic field then output will change to either 3.5mA (Downscale or 22mA (Upscale).

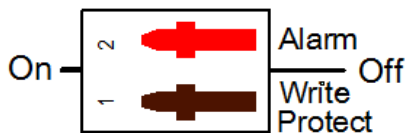

Fig. 6

Configuration switches

- 1) Write Protect
On: Range setting inhibited Off
- 2) Alarm Function
On: Low Level (3.8mA)
Off: No Alarm Output Remains at 4mA



Caution

Turn power off before changing alarm switch settings to prevent unexpected changes in loop current. Ensure that the write protect is set to 'ON' after changes to range adjustments.

Fixed Output

To allow for loop calibration the transmitter output can be fixed to either 4 or 20mA. The zero or span button should be depressed until the respective LED lights, the output will then remain static. To reset to normal operation either depress the opposite button or cycle the power.



Transmitter Front Panel Settings Flowchart

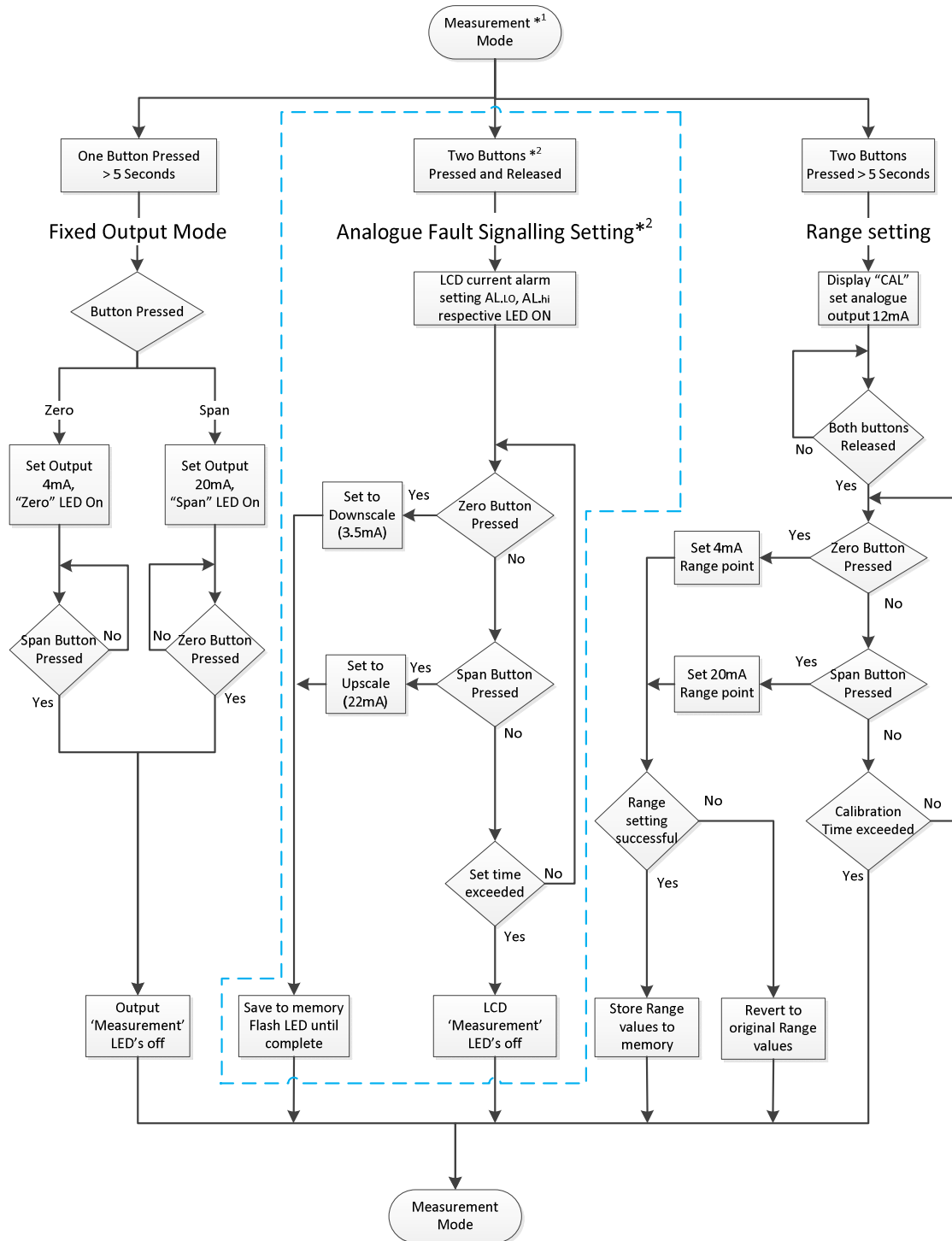

*1 Transmitter must be detecting float before settings can be changed

*2 Analogue fault signalling setting Rev5 onwards (Displayed during startup *Init.5*)

Certification

Certificate No's. Baseefa 06 ATEX 0159 X, BAS21UKEX0608X, IECEx BAS

06.0038 X Explosion protection Type: Ex ia

Gas Group: IIC or IIB

Approval Type:  I 1G Ex ia IIC T2 ... T6 Ga or II 1G Ex ia IIB T2 ... T6 Ga

Notified Body No. CE 0598

Approved Body No. UKCA 1180

Input Parameters Conn1 Terminal + w.r.t -

Ui = 28V, Ii = 93mA, Pi = 0.65W, Ci = 0, Li = 30uH.

Temperature Class

The relationship between the temperature class and maximum process temperature for the ambient temperature range is as shown in the following table.

| Temperature Class | Process Temperature | Ambient Temperature Range |
|-------------------|---------------------|---------------------------|
| T2 | ≤250°C | -50°C ≤ Ta ≤ 60°C |
| T3 | ≤195°C | |
| T4 | ≤130°C | |
| T5 | ≤95°C | |
| T6 | ≤80°C | -50°C ≤ Ta ≤ 40°C |

Table 2

Relationship between Temperature class,
process temperature, and ambient temperature

In accordance to EN60079-11:2012 clause 6.3.13 this apparatus is capable of withstanding a 500V isolation test.

EMC

In accordance to EU council directive 2014/30/EU

Emissions EN 61326:2004 (Class B)

| STANDARD | DESCRIPTION | PORT | RESULT |
|----------|---------------------|----------------|------------|
| EN 61326 | Radiated Emissions | Enclosure | Pass |
| EN 61326 | Conducted Emissions | Not applicable | Not Tested |

Immunity tests to EN 61326: 2004 A1, A2, A3

| STANDARD | DESCRIPTION | PORT | RESULT |
|------------|----------------------------|----------------|------------|
| 61000-4-2 | Electrostatic Discharge | Enclosure | Pass |
| 61000-4-3 | RF Electromagnetic Field | Enclosure | Pass |
| 61000-4-4 | EFT/ Burst | DC Port | Pass |
| 61000-4-5 | Surge | DC Port | Pass |
| 61000-4-6 | Conducted RF | DC Port | Pass |
| 61000-4-8 | Magnetic Field | Enclosure | Not Tested |
| 61000-4-11 | Voltage Dip/ interruptions | Not applicable | Not Tested |

Fault analysis Sheet

| Problem | Possible Fault | Action |
|---|--|---|
| Zero current eg. 0mA | Supply Voltage to low < 8V | Check voltage and adjust accordingly |
| | Supply Connections reversed | Swap supply cables |
| | Cables/Connecting circuit faulty | Rectify as required |
| | Faulty Unit | Consult Factory. |
| Current Greater than 22mA | Supply voltage to high > 28V | Adjust voltage to less than 28V |
| Output at 3.8mA (Low level) | Float damaged (sunk) | Fit new float |
| | Chamber empty | Open check valves |
| Continual reading of either 3.58mA Downscale 22mA Upscale | Float magnetic field not being sensed | Check gap distance between chamber and transmitter |
| | Float Under magnetised | Check with spare float if available |
| Output static at a particular level | Float stuck or damaged | Check against visual display if fitted. Check float condition |
| | Residual magnetic interference | Run magnet along full length of probe, Consult Factory. |
| | External magnetic interference | Check for external magnetic devices in vicinity. |
| 4-20mA not proportional to liquid level | "XXXX" marks not in line with vessel connections | Realign transmitter marks correctly |
| | S.G range of float incorrect for media type | Check S.G etched on float against media S.G |

Table 3
Fault Analysis

Maintenance

The unit contains no user serviceable parts; therefore no routine maintenance is required. Dependent on model or application:

For coated options:

- Where the case of the device may be subjected to impact or friction, periodic examination is required to ensure that the integrity of the stove enamelled finish is maintained.

For Immersion Applications

- The sensor tube must be kept clean to prevent the float "sticking".

Technical Data

Materials

Measuring probe: - Housing: 316L Stainless steel
- 316L Stainless steel

Cable entry

Thread Size: - M20x1.5mm
Connection conductor size: - 0.5mm² - 2.5mm²

Supply voltage (Nominal 24VDC)

Minimum 12V
Maximum 28V

Current Output

Measured Current range: - 4-20mA ± 0.1%

Fault Current: - Upscale*

Downscale 22mA
Low level (When enabled) 3.5mA
* Default Factory setting 3.8mA

Fixed Output (For loop calibration) 4 or 20mA ± 0.1%

Operating Temperatures

(See certification section for details when used in a potentially explosive atmosphere)

Ambient range: - -50°C / + 60°C (-30°C / +60°C When LCD Fitted)
Process range: - -50°C/ +250°C

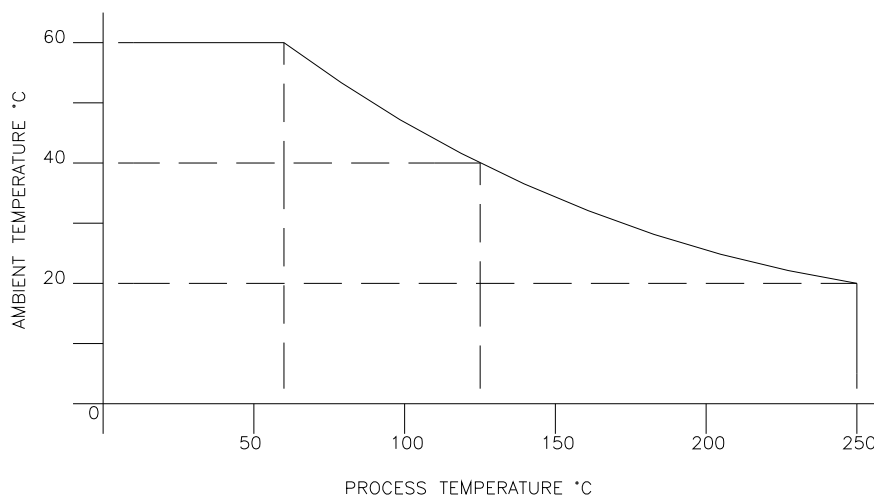

Fig 7

Ambient versus process temperature for standard transmitter
Where ambient conditions are outside this range additional insulation or shielding will be required please consult sales office.

Manufacturer

WIKA Instruments Limited
TC Fluid Control Level Division
Unit 7 Goya Business Park The
Moor Road,
Sevenoaks,
Kent TN14 5GY

Tel: +44 (0) 1322 622400
Fax: +44 (0) 1322 660621
Website: www.tc-fluidcontrol.com

E-Mail:
instruments@tc-fluidcontrol.com

Head Office

WIKA Instruments Limited
Unit 7 Goya Business Park
The Moor Road,
Sevenoaks,
Kent TN14 5GY

Tel: +44(0) 1737 644008
Fax: +44(0) 1737 644403
Website: www.wika.co.uk

E-Mail:
info@wika.co.uk

EU Importer

WIKA Alexander Wiegand SE &
Co. KG,
Alexander-Wiegand-Straße 30,
63911 Klingenberg,
Germany

Tel: +49 9372 132-0
Fax: +49 9372 132-406
Website: www.wika.de

E-Mail:
info@wika.de



Smart in sensing