

Threaded thermowell

Design per DIN 43772 form 6, 7, 9

Model TW50

WIKA data sheet TW 95.50

Applications

- Chemical industry, process technology, equipment manufacturing
- For high process loads

Special features

- Designs per DIN 43772
- Design TW50-H: Form 6
- Design TW50-I: Form 7
- Design TW50-J: Form 9

Description

Each thermowell/protection tube is an important component of any temperature measuring location. It is used to separate the process from the surrounding area, thus protecting the environment and operating personnel and keeps aggressive media, high pressures and flow rates from the temperature probe itself and thereby enables the thermometer to be exchanged during operation.

Based on the almost limitless application possibilities, there are a large number of variants, such as thermowell designs or materials. The type of process connection and the basic method of manufacture are important design differentiation criteria. A basic differentiation can be made between threaded and weld-in thermowells/protection tubes, and those with flange connections.

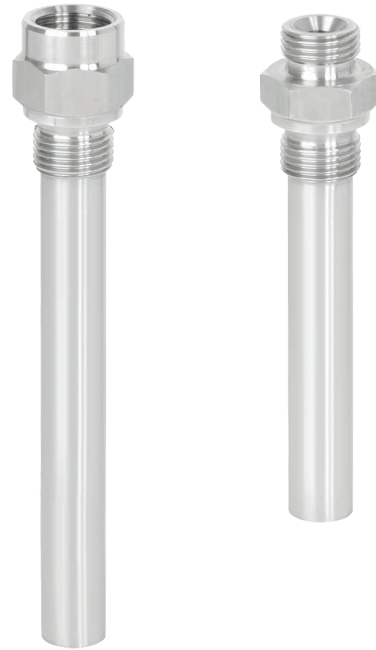

Fig. left: Design TW50-H
Fig. right: Design TW50-J

Furthermore, one can differentiate between protection tubes and thermowells. Protection tubes are constructed from a tube, that is closed at the tip by a welded solid tip. Thermowells are manufactured from solid bar stock.

The TW50 series of threaded thermowells are suitable for use with numerous mechanical and electrical thermometers from WIKA.

Due to their design to DIN 43772, these thermowells for high process loads are suitable for use in the chemical industry, process technology and equipment manufacturing.

Specifications

Basic information	
Design (per DIN 43772)	
Design TW50-H	Form 6
Design TW50-I	Form 7
Design TW50-J	Form 9
Material (wetted)	Stainless steel 1.4571
	Other materials on request

Process connection			
Type of process connection			
Designs TW50-H, TW50-J	<ul style="list-style-type: none"> ■ G ½ B male thread ■ G ¾ B male thread 		
Design TW50-I	<ul style="list-style-type: none"> ■ ½ NPT male thread ■ ¾ NPT male thread ■ 1 NPT male thread 		
Connection to thermometer			
Design TW50-H	<ul style="list-style-type: none"> ■ G ½ female thread ■ G ¾ female thread 		
Design TW50-I	G ½ female thread		
Design TW50-J	<ul style="list-style-type: none"> ■ G ½ B male thread ■ G ¾ B male thread 		
Bore size	<ul style="list-style-type: none"> ■ Ø 7 mm [0.28 in] ■ Ø 9 mm [0.35 in] ■ Ø 11 mm [0.43 in] 		
Insertion length U			
Designs TW50-H, TW50-I	<ul style="list-style-type: none"> ■ 82 mm [3.23 in] ■ 142 mm [5.59 in] ■ 182 mm [7.17 in] ■ 232 mm [9.13 in] ■ 382 mm [15.04 in] 		
Design TW50-J	<ul style="list-style-type: none"> ■ 73 mm [2.87 in] ■ 110 mm [4.33 in] ■ 170 mm [6.69 in] ■ 260 mm [10.24 in] ■ 410 mm [16.14 in] 		
Overall length L	Insertion length $U_1 + 28 \text{ mm}$ [1.1 in]		
Suitable stem lengths l_1 (dial thermometers)			
Design TW50-H	Connection design S, 4 or 5	$l_1 = L - 10 \text{ mm}$ [0.4 in] or $l_1 = U_1 + 18 \text{ mm}$ [0.7 in]	
	Connection design 2	$l_1 = L - 30 \text{ mm}$ [1.2 in] or $l_1 = U_1 - 2 \text{ mm}$ [0.1 in]	
Design TW50-J	Connection design 3	$l_1 = L - 12 \text{ mm}$ [0.5 in] or $l_1 = U_1 + 16 \text{ mm}$ [0.6 in]	
Suitable stem lengths l_1 (machine glass thermometer)			
Design TW50-H	Connection design E	Process connection (thermometer): all	$l_1 = L - 10 \text{ mm}$ [0.4 in] or $l_1 = U_1 + 18 \text{ mm}$ [0.7 in]
	Connection design 3	Process connection (thermometer): G ½	$l_1 = L - 12 \text{ mm}$ [0.5 in] or $l_1 = U_1 + 16 \text{ mm}$ [0.6 in]
Design TW50-J	Connection design 3	Process connection (thermometer): G ¾	$l_1 = L - 8 \text{ mm}$ [0.3 in] or $l_1 = U_1 + 20 \text{ mm}$ [0.8 in]

Operating conditions	
Max. process temperature, process pressure	Depending on: <ul style="list-style-type: none"> ■ Load diagram DIN 43772 ■ Thermowell design <ul style="list-style-type: none"> - Dimensions - Material ■ Process conditions <ul style="list-style-type: none"> - Flow rate - Medium density
Wake frequency calculation (option)	The calculation in accordance with Dittrich/Klotter or ASME PTC 19.3 TW-2016 of individual thermowells minimises the risk of dynamic damage that can be caused by the vortex shedding of a Kármán vortex street (Vortex Induced Vibration; VIV). In addition, the static loads due to lateral flow and the process pressure are calculated depending on the temperature. The calculation will be carried out as a WIKA engineered service (subject to charges).
	→ For further information, see Technical information IN 00.15 "Wake frequency calculation".

Certificates (option)

Certificates	
Certificates	<ul style="list-style-type: none"> ■ 2.2 test report ■ 3.1 inspection certificate

Approvals and certificates, see website

Dimensions in mm [in]

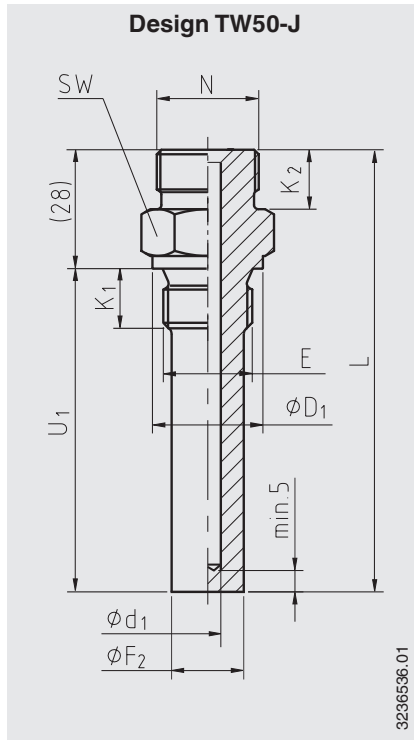
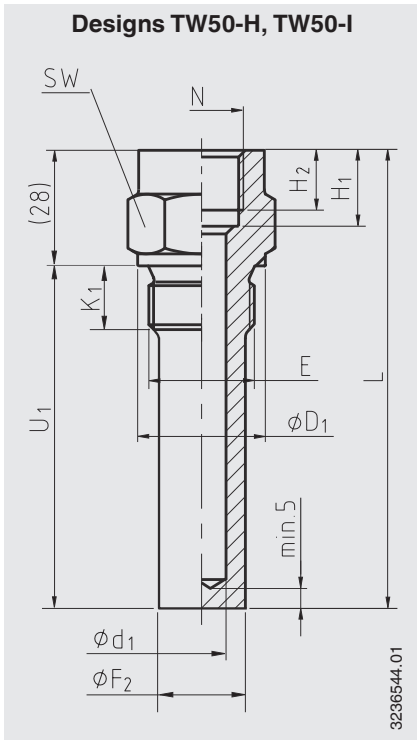

- Legend:
- E Process connection
 - H₁ Bore depth for female thread
 - H₂ Length of female thread
 - K₁ Length of stud end
 - K₂ Length of male thread for thermometer connection
 - L Overall length
 - N Connection to thermometer
 - SW Spanner width
 - U₁ Insertion length
 - Ø d₁ Bore size
 - Ø D₁ Diameter of the sealing collar
 - Ø F₂ Thermowell outer diameter

Design TW50-J

Dimensions in mm [in]								Weight in kg [lbs]	
E	N	Ø d ₁	Ø D ₁	Ø F ₂	K ₁	K ₂	SW	U ₁ = 73 mm [2.87 in]	U ₁ = 410 mm [16.14]
G ½ B	G ½ B	7 [0.28]	26 [1.02]	17 [0.67]	14 [0.55]	12 [0.47]	27 [1.06]	0.22 [0.49]	0.72 [1.59]
	G ½ B	9 [0.35]	26 [1.02]	17 [0.67]	14 [0.55]	12 [0.47]	27 [1.06]	0.20 [0.44]	0.64 [1.41]
	G ½ B	11 [0.43]	26 [1.02]	17 [0.67]	14 [0.55]	12 [0.47]	27 [1.06]	0.18 [0.40]	0.53 [1.17]
G ¾ B	G ¾ B	7 [0.28]	32 [1.26]	17 [0.67]	16 [0.63]	14 [0.55]	32 [1.26]	0.31 [0.68]	0.79 [1.74]
	G ¾ B	9 [0.35]	32 [1.26]	17 [0.67]	16 [0.63]	14 [0.55]	32 [1.26]	0.29 [0.64]	0.71 [1.57]
	G ¾ B	11 [0.43]	32 [1.26]	19 [0.75]	16 [0.63]	14 [0.55]	32 [1.26]	0.29 [0.64]	0.78 [1.72]

Designs TW50-H, TW50-I

Model	Dimensions in mm [in]									Weight in kg [lbs]	
	E	N	Ø d ₁	Ø D ₁	Ø F ₂	H ₁	H ₂	K ₁	SW	U ₁ = 82 mm [3.23 in]	U ₁ = 382 mm [15.04 in]
TW50-H	G ½ B	G ½ B	7 [0.28]	26 [1.02]	17 [0.67]	19 [0.75]	15 [0.59]	14 [0.55]	27 [1.06]	0.22 [0.49]	0.67 [1.48]
	G ½ B	G ½ B	9 [0.35]	26 [1.02]	17 [0.67]	19 [0.75]	15 [0.59]	14 [0.55]	27 [1.06]	0.21 [0.46]	0.59 [1.3]
	G ½ B	G ½ B	11 [0.43]	26 [1.02]	17 [0.67]	19 [0.75]	15 [0.59]	14 [0.55]	27 [1.06]	0.19 [0.42]	0.50 [1.1]
	G ¾ B	G ½ B	7 [0.28]	32 [1.26]	17 [0.67]	19 [0.75]	15 [0.59]	16 [0.63]	32 [1.26]	0.28 [0.62]	0.72 [1.59]
	G ¾ B	G ½ B	9 [0.35]	32 [1.26]	17 [0.67]	19 [0.75]	15 [0.59]	16 [0.63]	32 [1.26]	0.27 [0.6]	0.65 [1.43]
	G ¾ B	G ½ B	11 [0.43]	32 [1.26]	19 [0.75]	19 [0.75]	15 [0.59]	16 [0.63]	32 [1.26]	0.25 [0.55]	0.63 [1.39]
	G ¾ B	G ¾ B	7 [0.28]	32 [1.26]	17 [0.67]	22 [0.87]	17 [0.67]	16 [0.63]	32 [1.26]	0.31 [0.68]	0.82 [1.81]
	G ¾ B	G ¾ B	9 [0.35]	32 [1.26]	17 [0.67]	22 [0.87]	17 [0.67]	16 [0.63]	32 [1.26]	0.30 [0.66]	0.75 [1.65]
	G ¾ B	G ¾ B	11 [0.43]	32 [1.26]	19 [0.75]	22 [0.87]	17 [0.67]	16 [0.63]	32 [1.26]	0.29 [0.64]	0.74 [1.63]
TW50-I	½ NPT-14	G ½ B	7 [0.28]	32 [1.26]	17 [0.67]	19 [0.75]	15 [0.59]	≈ 20 [0.79]	27 [1.06]	0.22 [0.49]	0.67 [1.48]
	½ NPT-14	G ½ B	9 [0.35]	32 [1.26]	17 [0.67]	19 [0.75]	15 [0.59]	≈ 20 [0.79]	27 [1.06]	0.21 [0.46]	0.59 [1.3]
	½ NPT-14	G ½ B	11 [0.43]	32 [1.26]	17 [0.67]	19 [0.75]	15 [0.59]	≈ 20 [0.79]	27 [1.06]	0.19 [0.42]	0.50 [1.1]
	¾ NPT-14	G ½ B	7 [0.28]	32 [1.26]	17 [0.67]	19 [0.75]	15 [0.59]	≈ 21 [0.83]	27 [1.06]	0.24 [0.53]	0.69 [1.52]
	¾ NPT-14	G ½ B	9 [0.35]	32 [1.26]	17 [0.67]	19 [0.75]	15 [0.59]	≈ 21 [0.83]	27 [1.06]	0.23 [0.51]	0.61 [1.34]
	¾ NPT-14	G ½ B	11 [0.43]	32 [1.26]	19 [0.75]	19 [0.75]	15 [0.59]	≈ 21 [0.83]	27 [1.06]	0.21 [0.46]	0.52 [1.15]
	1 NPT-11.5	G ½ B	7 [0.28]	32 [1.26]	17 [0.67]	19 [0.75]	15 [0.59]	≈ 25 [0.98]	36 [1.42]	0.32 [0.71]	0.85 [1.87]
	1 NPT-11.5	G ½ B	9 [0.35]	32 [1.26]	20 [0.79]	19 [0.75]	15 [0.59]	≈ 25 [0.98]	36 [1.42]	0.30 [0.66]	0.75 [1.65]
	1 NPT-11.5	G ½ B	11 [0.43]	32 [1.26]	22 [0.87]	19 [0.75]	15 [0.59]	≈ 25 [0.98]	36 [1.42]	0.29 [0.64]	0.74 [1.63]

Pressure-temperature diagram ¹⁾

Thermowell model TW50 made of stainless steel 1.4571

U₁ = 232 mm [9.13 in] mit Ø F₂ = 17 mm [0.67 in] and Ø d₁ = 7 mm [0.28 in]

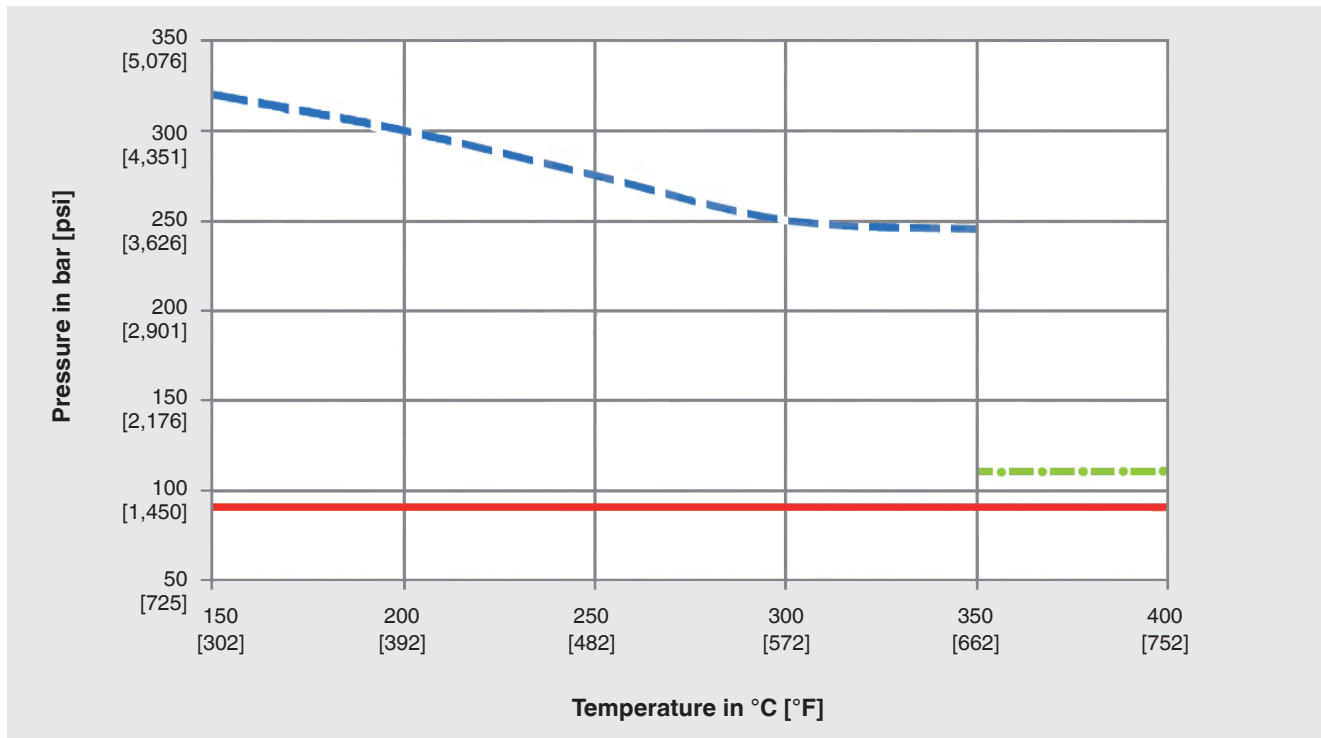

- 1) Rating depends on the parameters below:
- Process medium
 - Process pressure and temperature
 - Flow rate
 - Thermowell design (dimensions, material)

Legend:

- Water 3 m/s
- Air 40 m/s
- Vapour 40 m/s

Ordering information

Model / Thermowell form / Thermowell material / Process connection / Connection to thermometer / Insertion length U₁ / Bore size Ø d₁ / Assembly with thermometer / Certificates / Options

© 12/2007 WIKA Alexander Wiegand SE & Co. KG, all rights reserved.
 The specifications given in this document represent the state of engineering at the time of publishing.
 We reserve the right to make modifications to the specifications and materials.



WIKA Alexander Wiegand SE & Co. KG
 Alexander-Wiegand-Straße 30
 63911 Klingenberg/Germany
 Tel. +49 9372 132-0
 info@wika.de
 www.wika.de