

Protection tube with flange

Version per DIN 43772 form 2F, 3F

Model TW40

WIKA data sheet TW 95.40

Applications

- Chemical industry, process technology, equipment manufacturing
- For low and medium process loads
- For high chemical loads

Special features

- For highly corrosion-resistant coating (models TW40-8, TW40-9)
- Good price/performance ratio for special materials
- Fast-response design (models TW40-9, TW40-E)

Description

Each thermowell/protection tube is an important component of any temperature measuring location. It is used to separate the process from the surrounding area, thus protecting the environment and operating personnel and keeps aggressive media, high pressures and flow rates from the temperature probe itself and thereby enables the thermometer to be exchanged during operation.

Based on the almost limitless application possibilities, there are a large number of variants, such as protection tube designs or materials. The type of process connection and the basic method of manufacture are important design differentiation criteria. A basic differentiation can be made between threaded and weld-in protection tubes, and those with flange connections.

Furthermore, one can differentiate between protection tubes and thermowells. Protection tubes are constructed from a tube, that is closed at the tip by a welded solid tip. Thermowells are manufactured from solid bar stock.



Fig. left: Protection tube with flange, model TW40-8
Fig. right: Protection tube with tantalum cover, model TW40-E

The TW40 series of protection tubes with flange connection are suitable for use with numerous electrical and mechanical thermometers from WIKA.

Due to their design to DIN 43772, these protection tubes for low and medium process loads are suitable for use in the chemical industry, process technology and equipment manufacturing.

Specifications

Basic information	
Protection tube form	<ul style="list-style-type: none"> ■ Straight ■ Tapered design
Design	
Design TW40-8	Per DIN 43772 form 2F (straight tube)
Design TW40-9	Per DIN 43772 form 3F (tapered tube)
Design TW40-D	Per DIN 43772 form 2F, special materials
Design TW40-E	Per DIN 43772 form 3F, with tantalum cover
Material (wetted)	<ul style="list-style-type: none"> ■ Stainless steel 1.4571 ■ Alloy C4 ■ Alloy C276 ■ Alloy 400 ■ Titanium grade 2 ■ Tantalum <p>Other materials on request</p>
Coating (only designs TW40-8, TW40-9)	<ul style="list-style-type: none"> ■ PFA Layer thickness min. 0.4 mm [0.015 in] (standard) or min. 0.6 mm [0.024 in] (special design) ■ ECTFE (Halar®) Layer thickness min. 0.6 mm [0.024 in]

Halar® ECTFE is a registered trademark of the company Solvay Solexis.

Process connection			
Type of process connection	Flanges to valid national or international standards like e.g. EN 1092-1, DIN 2527, ASME B16.5		
Flange disc (design TW40-E, TW40-D)	<ul style="list-style-type: none"> ■ Per EN 1092-1 with sealing face form B1 ■ Per DIN 2527 with sealing face form C per DIN 2526 ■ Per ASME B16.5 with sealing face form RF (smooth sealing face with tantalum) 		
Connection to thermometer	<ul style="list-style-type: none"> ■ M24 x 1.5 (rotatable threaded connection, male nut) ■ G ½ female thread ■ ½ NPT female thread ■ M20 x 1.5 female thread 		
Bore size Ø d₁	Tube	Inner diameter	For probes
Design TW40-8	9 x 1 mm [0.35 x 0.04 in]	7.0 mm [0.28 in]	6 mm [0.24 in]
	11 x 2 mm [0.43 x 0.08 in]	7.0 mm [0.28 in]	6 mm [0.24 in]
	12 x 1.5 mm [0.47 x 0.06 in]	9.0 mm [0.35 in]	8 mm [0.31 in]
	12 x 2.5 mm [0.47 x 0.09 in]	7.0 mm [0.28 in]	6 mm [0.24 in]
	14 x 2.5 mm [0.55 x 0.10 in]	9.0 mm [0.35 in]	8 mm [0.31 in]
	15 x 2 mm [0.59 x 0.08 in]	11.0 mm [0.43 in]	10 mm [0.4 in]
Design TW40-9	12 x 2.5 mm [0.47 x 0.09 in] to 9 mm [0.35 in]	6.1 mm [0.24 in]	6 mm [0.24 in]
Design TW40-D	13.7 x 2.2 mm [0.54 x 0.09 in]	9.3 mm [0.37 in]	6 mm [0.24 in] or 8 mm [0.31 in]
Design TW40-E	11 x 2 mm [0.43 x 0.08 in] with tantalum cover	7.0 mm [0.28 in]	6 mm [0.24 in]
	15 x 3 mm [0.59 x 0.12 in] with tantalum cover	9.0 mm [0.35 in]	8 mm [0.31 in]
	12 x 2.5 mm [0.47 x 0.09 in] to 9 mm [0.35 in] with tantalum cover	6.1 mm [0.24 in]	6 mm [0.24 in]
Insertion length U₁	50 ... 3,500 mm [1.9 ... 137.8 in]		

Process connection				
Overall length L				
Designs TW40-8, TW40-D ¹⁾ , TW40-E ¹⁾	Insertion length $U_1 + 80$ mm [3.15 in]			
Design TW40-9	Insertion length $U_1 + 82$ mm [3.23 in]			
Suitable stem length l_1 (dial thermometer)				
Connection design S, 4, 4.1, 5, 6.1, 6.2, 6.3 and 7	Parallel thread	$l_1 = L - 10$ mm [0.4 in] or $l_1 = U_1 + M - 10$ mm [0.4 in]		
	Tapered thread	$l_1 = U_1 + M - 2$ mm [0.08 in]		
Connection design 2	$l_1 = L - 30$ mm [1.2 in] or $l_1 = U_1 + M - 30$ mm [1.2 in]			
Connection design 3	$l_1 = L - 10$ mm [0.4 in] or $l_1 = U_1 + M - 10$ mm [0.4 in]			
Sealing face roughness	Design	AARRH in μinch	Ra in μm	Rz in μm
ASME B16.5	Stock finish	125 ... 250	3.2 ... 6.3	-
	Smooth finish	< 125	< 3.2	-
	RTJ	< 63	< 1.6	-
	Groove/tongue	< 125	< 3.2	-
EN 1092-1	Form B1	-	3.2 ... 12.5	12.5 ... 50
	Form B2	-	0.8 ... 3.2	3.2 ... 12.5
DIN 2527	Form C	-	-	40 ... 160
	Form E	-	-	< 16

1) For versions with tantalum cover, the insertion length will be longer by up to 3 mm [0.12 in]

Operating conditions	
Max. process temperature, process pressure	Depending on: <ul style="list-style-type: none"> ■ Load diagram DIN 43772 ■ Protection tube design <ul style="list-style-type: none"> - Dimensions - Material - Coating ■ Process conditions <ul style="list-style-type: none"> - Flow rate - Density of medium
Wake frequency calculation (option)	<p>The calculation in accordance with ASME PTC 19.3 TW-2016 of individual thermowells minimises the risk of dynamic damage that can be caused by the vortex shedding of a Kármán vortex street (Vortex Induced Vibration; VIV). In addition, the static loads due to lateral flow and the process pressure are calculated depending on the temperature.</p> <p>The calculation can be carried out independently using an online tool or as a WIKA engineered service (subject to charges).</p> <p>→ For further information, see Technical information IN 00.15 "Wake frequency calculation".</p>

Dimensions in mm [in]

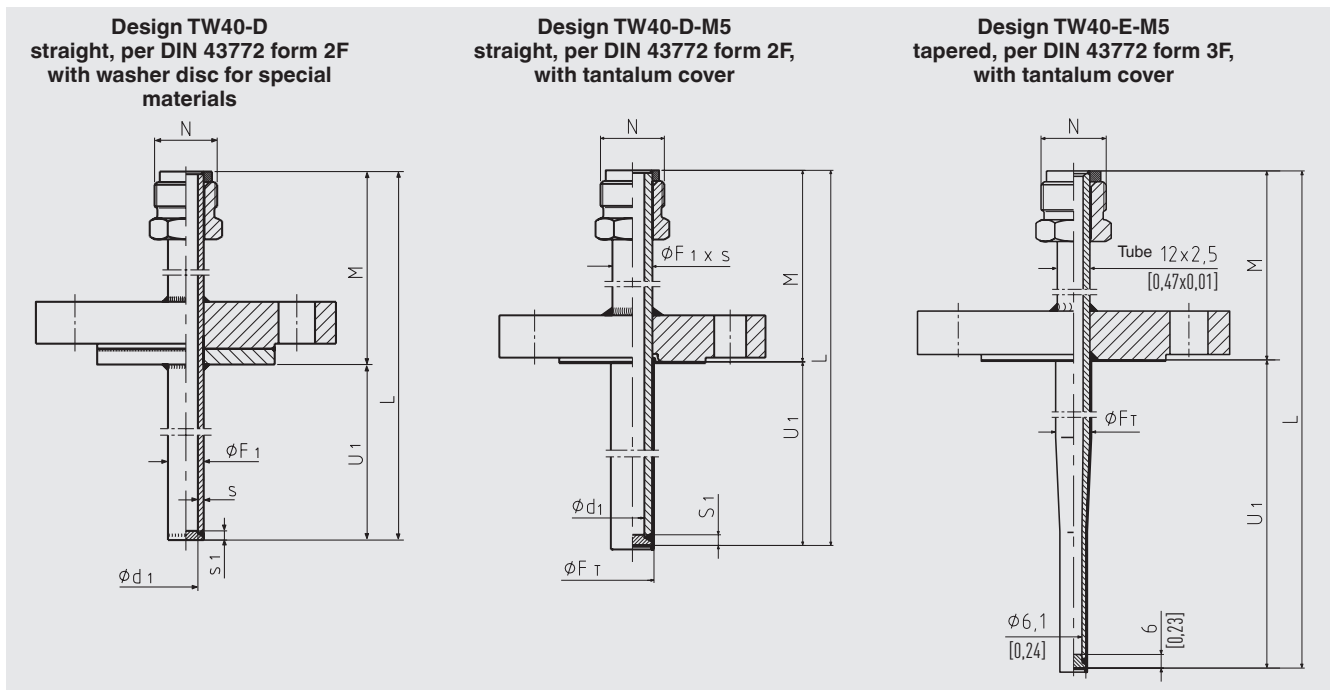
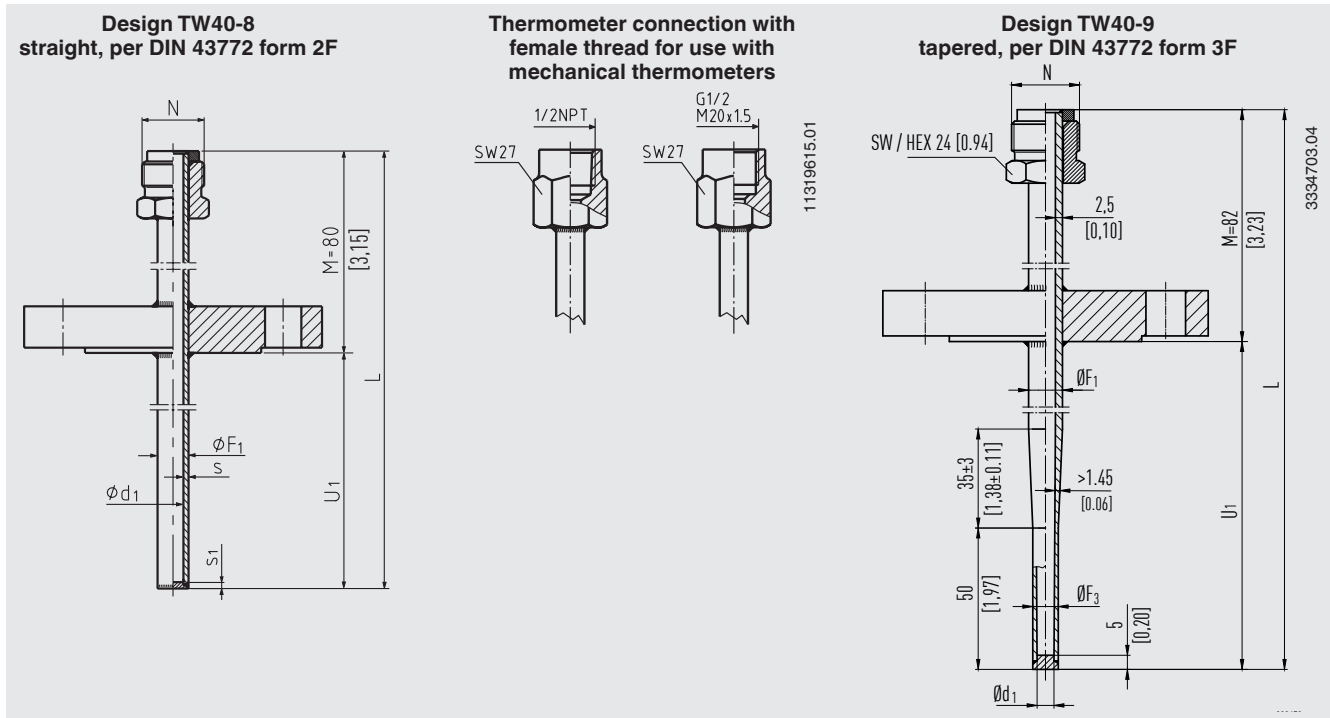

Legend:

- L Overall length
- M Neck tube length (min. 60 mm [2.36 in])
- U₁ Insertion length
- N Connection to thermometer
- Ø d₁ Bore size
- Ø F₁ Protection tube outer diameter
- Ø F_T Outer diameter of tantalum cover
- S Wall thickness
- S₁ Tip thickness

Dimensions in mm [in]	Weight in kg [lbs]
$\varnothing F_1 \times S$	Flange DN 25 PN 16 ... 40 $U_1 = 225 \text{ mm [8.86 in]}$
9 x 1 [0.35 x 0.04]	1.39 [3.06]
11 x 2 [0.43 x 0.08]	1.55 [3.42]
12 x 1,5 [0,47 x 0,06]	1,61 [3,55]
14 x 2.5 [0.55 x 0.1]	1.71 [3.77]
12 x 2.5 [0.47 x 0.09]	1.64 [3.62]
15 x 2 [0.59 x 0.08]	1.41 [3.11]
9.3 x 2.2 [0.36 x 0.09]	1.70 [3.75]

Additional weight with other flanges		
DN 40	PN 16 ... 40	+0.76 kg [+1.68 lbs]
DN 50	PN 16 ... 40	+1.63 kg [+3.59 lbs]
1"	150 lbs	-0.46 kg [-1.01 lbs]
1"	300 lbs	+0.04 kg [+0.09 lbs]
1"	600 lbs	+0.22 kg [+0.49 lbs]
1 ½"	150 lbs	+0.22 kg [+0.49 lbs]
1 ½"	300 lbs	+1.34 kg [+2.95 lbs]
1 ½"	600 lbs	+1.85 kg [+4.08 lbs]

Design TW40-D-M5 (tantalum)

Dimensions in mm [in]			Weight DN 25 ... 225 mm [0.98 ... 8.86 in]
$\varnothing F_T$	$\varnothing F_1 \times S$	S_1	
12 x 0.4 [0.47 x 0.02]	11 x 2 [0.43 x 0.08]	2.5 [0.1]	1.65
16 x 0.4 [0.63 x 0.02]	15 x 3 [0.59 x 0.12]	3.5 [0.14]	1.75
13 x 0.4 [0.51 x 0.02]	12 x 2.5 [0.47 x 0.1]	6 [0.24]	1.70

Ordering information

Model / Protection tube form / Protection tube material / Dimension of stem / Connection to the thermometer / Bore \varnothing d₁ / Nominal width DN / Pressure rating PN / Sealing face / Insertion length U₁ / Overall length L / Coating / Assembly with thermometer / Certificates / Options

© 12/2007 WIKA Alexander Wiegand SE & Co. KG, all rights reserved.
The specifications given in this document represent the state of engineering at the time of publishing.
We reserve the right to make modifications to the specifications and materials.



WIKA Alexander Wiegand SE & Co. KG
Alexander-Wiegand-Straße 30
63911 Klingenberg/Germany
Tel. +49 9372 132-0
info@wika.de
www.wika.de