

Bourdon tube pressure gauge OEM version Models 101.12.040, 101.12.050, 101.12.063

WIKA data sheet PM 01.30

Applications

- For gaseous and liquid media that are not highly viscous or crystallising and will not attack copper alloy parts and polyamide (PA)
- Pneumatics
- Heating and sanitary industries
- Air pumps, compressors
- Medical equipment

Special features

- Ideal for integration solutions
- Low weight
- Scale range from 0 ... 2.5 bar to 0... 25 bar or 0 ... 30 psi to 0 ... 300 psi
- Nominal sizes 40 [1 ½"], 50 [2"] and 63 [2 ½"] available
- Male process connections G ¼ B, R ⅛ and R ¼ available, other process connections on request



Fig. left: view from the front
Fig. right: view from the rear

Description

The design of this pressure gauge is cost-effective and specifically aimed at OEM customers. This instrument is based on a reliable Bourdon tube measuring system. Model 101.12 builds on the proven model 101.00 and differs by featuring a compact direct process connection instead of the capillary tube design. The modular brass measuring system guarantees low temperature influence and high measuring stability.

This proven design is ideal for applications with compact dimensions requiring small built-in pressure gauges.

WIKA as an OEM supplier

Secure supply chains, high quality standards and a comprehensive range of services worldwide make WIKA a reliable OEM supplier – especially for large volume orders. Model 101.12 pressure gauges are available directly, in high quantities, with customer-specific process connections. Special adaptations can be realised together – including brand labelling.

Specifications

Basic information	
Standard	In line with EN 837-1 → For information on the "Selection, installation, handling and operation of pressure gauges", see technical information IN 00.05.
Nominal size (NS)	<ul style="list-style-type: none"> ■ Ø 40 mm [1 ½"] ■ Ø 50 mm [2"] ■ Ø 63 mm [2 ½"]
Connection location	Centre back mount
Window	Plastic, crystal-clear, snap-fitted in case
Case	<ul style="list-style-type: none"> ■ Plastic, black ■ Plastic, white
Mounting	Customisable on request
Movement	Copper alloy

Measuring element	
Type of measuring element	Bourdon tube, C-type
Material	Copper alloy
Leak tightness	Leakage rate: $< 5 \cdot 10^{-3}$ mbar l/s

Accuracy specifications	
Accuracy class	
EN 837-1	Class 2.5
ASME B40.100	$\pm 3\%$ $\pm 2\%$ $\pm 3\%$ of measuring span (grade B)
Temperature error	On deviation from the reference conditions at the measuring system: $\leq \pm 0.4\%$ per $10\text{ }^\circ\text{C}$ [$\leq \pm 0.4\%$ per $18\text{ }^\circ\text{F}$] of full scale value
Reference conditions	
Ambient temperature	$+20\text{ }^\circ\text{C}$ [$+68\text{ }^\circ\text{F}$]

Scale ranges

bar	
0 ... 2.5	0 ... 12
0 ... 4	0 ... 16
0 ... 6	0 ... 25
0 ... 10	-

kg/cm ²	
0 ... 2.5	0 ... 12
0 ... 4	0 ... 16
0 ... 6	0 ... 25
0 ... 10	-

kPa	
0 ... 250	0 ... 1,000
0 ... 400	0 ... 1,600
0 ... 600	0 ... 2,500

MPa	
0 ... 2.5	0 ... 1
0 ... 0.4	0 ... 1.6
0 ... 0.6	0 ... 2.5

psi	
0 ... 30	0 ... 160
0 ... 60	0 ... 200
0 ... 100	0 ... 300
0 ... 150	-

Further details on: scale ranges	
Special scale ranges	→ Other scale ranges on request
Unit	<ul style="list-style-type: none"> ■ bar ■ psi ■ kg/cm² ■ kPa ■ MPa
Dial	
Scale colour	Black
Material	Plastic
Special scale	→ Other scales or customer-specific dials, e.g. with red mark, circular arcs or circular sectors, on request
Instrument pointer	Plastic, black
Pointer stop pin	At zero point

Process connection	
Standard	<ul style="list-style-type: none"> ■ EN 837-1 ■ ISO 7
Size	
EN 837-1	G ¼ B, male thread
ISO 7	<ul style="list-style-type: none"> ■ R ½, male thread ■ R ¼, male thread
Material (wetted)	
Bourdon tube	Copper alloy
Process connection	Polyamide (PA)

→ Other process connections on request

Operating conditions	
Medium temperature	Max. +60 °C [+140 °F]
Ambient temperature	-20 ... +60 °C [-4 ... +140 °F]
Pressure limitation	
Steady	¾ x full scale value
Fluctuating	⅔ x full scale value
Short time	Full scale value
Ingress protection per IEC/EN 60529	IP41

Certificates

Certificates	
Certificates	2.2 test report per EN 10204 (e.g. state-of-the-art manufacturing, indication accuracy)
Recommended calibration interval	1 year (dependent on conditions of use)

→ For approvals and certificates, see website

Dimensions in mm [in]

Model 101.12.040

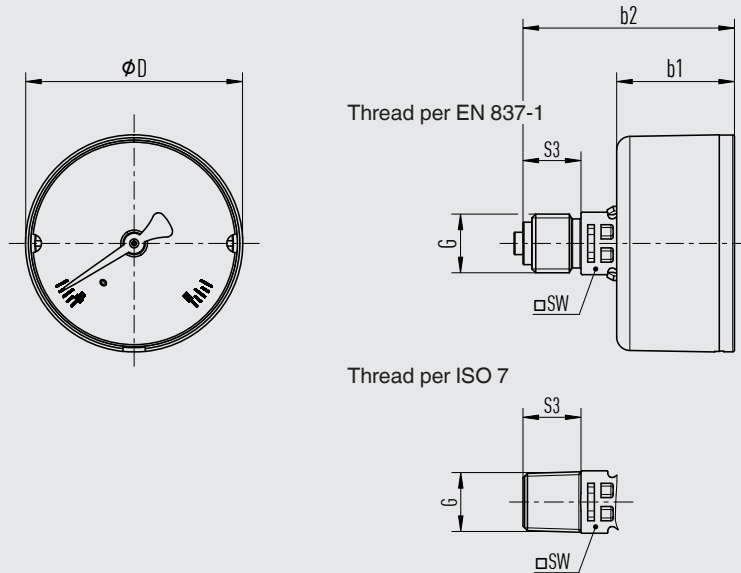

31 085938.03

NS	G	Dimensions in mm [in]				
		D	b1 ±0.5 [0.02]	b2 ±1 [0.04]	S3	SW
40 [1 ½"]	G ¼ B	41 [1.61]	26 [1.02]	47 [1.85]	13 [0.51]	14 [0.55]
	R ⅙	41 [1.61]	26 [1.02]	44 [1.73]	10 [0.39]	14 [0.55]
	R ¼	41 [1.61]	26 [1.02]	47 [1.85]	13 [0.51]	14 [0.55]
50 [2"]	G ¼ B	49 [1.93]	26.5 [1.04]	47,5 [1.87]	13 [0.51]	14 [0.55]
	R ⅙	49 [1.93]	26.5 [1.04]	44.5 [1.75]	10 [0.39]	14 [0.55]
	R ¼	49 [1.93]	26.5 [1.04]	47,5 [1.87]	13 [0.51]	14 [0.55]
63 [2 ½"]	G ¼ B	62 [2.44]	26.5 [1.04]	47,5 [1.87]	13 [0.51]	14 [0.55]
	R ⅙	62 [2.44]	26.5 [1.04]	44.5 [1.75]	10 [0.39]	14 [0.55]
	R ¼	62 [2.44]	26.5 [1.04]	47,5 [1.87]	13 [0.51]	14 [0.55]

NS	Weight in g [oz]
40 [1 ½"]	Approx. 22 [0.78]
50 [2"]	Approx. 29 [1.02]
63 [2 ½"]	Approx. 37 [1.31]

Ordering information

Model / Scale range / Process connection / Options

© 04/2026 WIKA Alexander Wiegand SE & Co. KG, all rights reserved.
The specifications given in this document represent the state of the art at the time of publishing.
We reserve the right to make modifications to the specifications and materials.

