

# Magnetostrictive level transmitter

## Version with local indication

### Models BLM-TB and BLM-TH

WIKA data sheet LM 10.07



For approvals, see  
page 4

#### Applications

- High-accuracy level detection for almost all liquid media in the process industry
- Suitable for interface layer applications or processes with heavy foaming
- Chemical, petrochemical industry, natural gas, offshore, shipbuilding, power generating equipment, power plants

#### Special features

- Insertion length 100 ... 6,000 mm [3.94 ... 236.22 in] (flexible version up to 22,000 mm [866.14 in])
- Version with LC display for local indication of the level (Version with heatable LC display for lower ambient temperatures on request)
- High accuracy of up to  $\pm 0.2$  mm [ $\pm 0.008$  in] or  $\pm 0.01$  % over the entire measuring range
- Very high resolution of  $< 0.1$  mm [0.004 in]
- Version for hazardous areas



Level transmitter with LC display, model BLM-TB

#### Description

The model BLM-TB magnetostrictive level transmitter is used for high-accuracy, continuous level detection of liquids, also with long insertion lengths.

The model BLM-TB has a local LC display. For particularly low ambient temperatures, the model BLM-TH version can be used, which has a heated LC display.

Furthermore, the model BLM-TB and BLM-TH level transmit-

ters with LC display are available as both an intrinsically safe version and a version with flameproof enclosure.

# Specifications

## Functionality

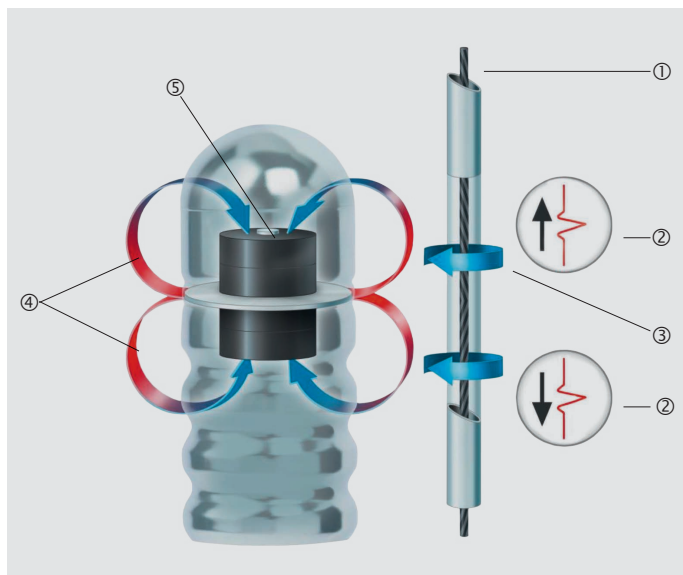

- ① Wire
- ② Torsional wave
- ③ Impulse magnetic field
- ④ Permanent magnetic field
- ⑤ Permanent magnetic field

## Design and operating principle

- The measurement process is triggered by a current impulse. This current produces a circular magnetic field along a wire made of magnetostrictive material which is held under tension inside the corrugated tube.
- At the point being measured (liquid level) there is a float with permanent magnets acting as a position transducer.
- The superposition of these two magnetic fields triggers a mechanical torsional wave in the wire.
- This is converted into an electrical signal at the end of the wire in the sensor housing by a piezoceramic converter.
- The measured propagation delay enables the origination point of the mechanical wave, and thus the float position, to be determined with high accuracy.



## Overview of versions

Model	Display	Electrical connection	Ex version
BLM-TB	LC display	Cable gland	-
BLM-TBI	LC display	Cable gland	Ex ia
BLM-TBD	LC display	Cable gland	Ex ia/db
BLM-TH	LC display with integrated heating	Cable gland	-
BLM-THI	LC display with integrated heating	Cable gland	Ex ia
BLM-THD	LC display with integrated heating	Cable gland	Ex ia/db



Basic information		
<b>Connection housing</b>		
Material	Stainless steel 1.4404 (316L), safety glass	
<b>Sensor tube</b>		
Material	Stainless steel 1.4571 (316Ti) Further materials such as Hastelloy on request	
Diameter	12 mm [0.47 in]	
Sensor length	Rigid version	100 ... 6,000 mm [3.937 ... 236.221 in]
	Flexible version (with corrugated tube)	1,500 ... 22,000 mm [59.055 ... 866.142 in]
Upper dead band (sensor housing)	100 mm [3.94 in]	
Lower dead band (sensor end)	50 mm [1.97 in]	
Measuring range	Sensor length – upper and lower dead band (150 mm [5.91 in])	
<b>Accuracy specifications</b>		
Level	Up to $\pm 0.2$ mm [0.008 in] or $\pm 0.01$ %	
Resolution (HART®)	0.1 mm [0.004 in]	
Mounting fixture <sup>1)</sup>	<ul style="list-style-type: none"> <li>■ Welded retaining bracket</li> <li>■ Tightening straps</li> <li>■ Tightening straps with welded retaining bracket</li> </ul>	
<b>Output signal</b>		
Output signal	4 ... 20 mA (3.8 ... 20.5 mA) / HART® version 6	
<b>Residual current</b>		
Residual current	3.6 mA or 21.5 mA (adjustable)	
<b>Electrical connection</b>		
Connection type	2-wire	
Cable diameter	5 ... 10 mm [0.2 ... 0.39 in]	
Supply voltage	Standard (non-Ex)	DC 12 ... 50 V
	Intrinsically safe version (Ex ia)	DC 12 ... 30 V
	Flameproof version (Ex db)	DC 12 ... 50 V
	Heating (model BLM-TH)	DC 24 V ( $\pm 10$ %)
Electrical output	<ul style="list-style-type: none"> <li>■ Cable bushing M20 x 1.5</li> <li>■ Cable gland M20 x 1.5</li> <li>■ ½ NPT thread for conduit wiring</li> </ul>	
<b>Operating conditions</b>		
Ambient temperature range	BLM-TB	-20 ... +85 °C [-40 ... +185 °F]
	BLM-TH	-55 ... +85 °C [-67 ... +185 °F] (with integrated heating)
Storage temperature range	-40 ... +85 °C [-40 ... +185 °F]	
Surface temperature range of the sensor tube	Normal temperature (NT)	-40 ... +125 °C [-40 ... +257 °F]
	High temperature (HT)	-40 ... +250 °C [-40 ... +482 °F]
	Highest temperature (HHT)	-40 ... +450 °C [-40 ... +842 °F]
	Low temperature (LT)	-65 ... +125 °C [-85 ... +257 °F]
Ingress protection per IEC/EN 60529	IP66/68	

1) Mounting fixture for installation of the level transmitter at a model BNA bypass level indicator, see data sheet LM 10.01

## Approvals

Logo	Description	Region
	<b>EU declaration of conformity</b>	European Union
	EMC Directive EN 61326 emission (group 1, class B) and immunity (industrial environments)	
	RoHS directive	
	<b>UKCA</b>	United Kingdom
	Electromagnetic compatibility regulations	
	Restriction of hazardous substances (RoHS) regulations	

## Optional approvals

Logo	Description	Region
	<b>EU declaration of conformity</b>	European Union
	ATEX directive Hazardous areas - Ex i Zone 0 gas Zone 0/1 gas Zone 1 gas Zone 1 dust - Ex db Zone 0/1 gas Zone 1 gas Zone 1 dust II 1G Ex ia IIC T6 ... T1 Ga II 1/2G Ex ia IIC T6 ... T1 Ga/Gb II 2G Ex ia IIC T6 ... T1 Gb II 2D Ex ia IIIC TX °C Db (see thermal data on approval certificate) II 1/2G Ex ia/db IIC T6 ... T1 Ga/Gb II 2G Ex db ia IIC T6 ... T1 Gb II 2D Ex ia tb IIIC TX °C Db (see thermal data on approval certificate)	
	<b>IECEX</b>	International
	Hazardous areas - Ex ia Zone 0 gas Zone 0/1 gas Zone 1 gas Zone 1 dust - Ex db Zone 0/1 gas Zone 1 gas Zone 1 dust Ex ia IIC T6 ... T1 Ga Ex ia IIC T6 ... T1 Ga/Gb Ex ia IIC T6 ... T1 Gb Ex ia IIIC TX °C Db (see thermal data on approval certificate) Ex ia/db IIC T6 ... T1 Ga/Gb Ex db ia IIC T6 ... T1 Gb Ex ia tb IIIC TX °C Db (see thermal data on approval certificate)	

## Manufacturer's declaration

Logo	Description
	<b>SIL 2</b> Functional safety
-	<b>China RoHS directive</b>

## Certificates

Certificates	
<b>Certificates</b>	<ul style="list-style-type: none"> <li>■ 2.2 test report per EN 10204 (e.g. state-of-the-art manufacturing, material proof, indication accuracy)</li> <li>■ 3.1 inspection certificate per EN 10204 (e.g. material proof for wetted metal parts, indication accuracy, calibration certificate)</li> </ul>

→ For approvals and certificates, see website

# Dimensions in mm [in]

## Version with process connection flange

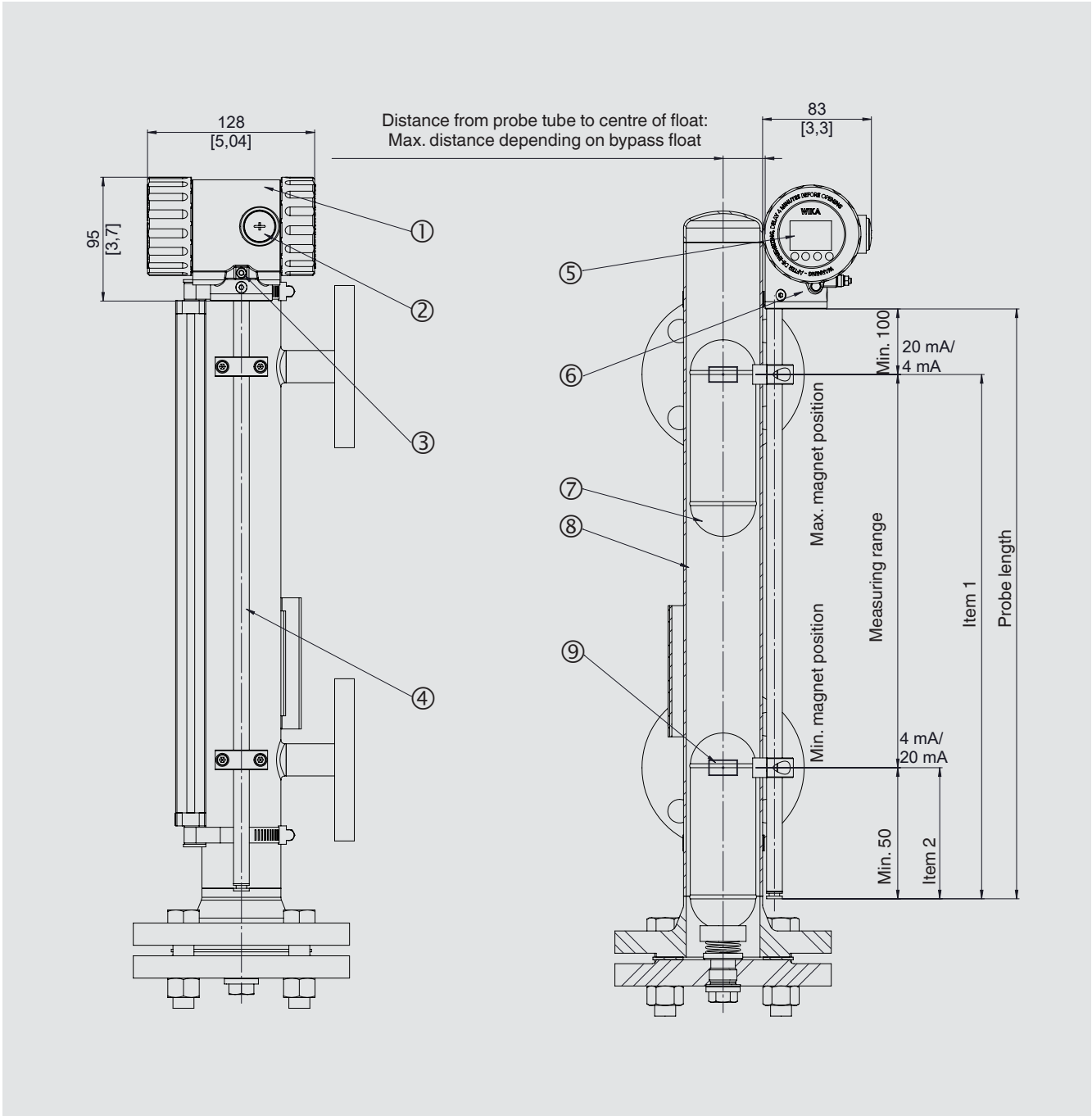

- ① Probe head
- ② Plug screw M20 x 1.5
- ③ Grounding connection
- ④ Probe tube, mounted free of tension (not deformed)
- ⑤ Display unit
- ⑥ Lock screw
- ⑦ Bypass float
- ⑧ Bypass tube
- ⑨ Magnet position

## Orientation of BLM-TBD

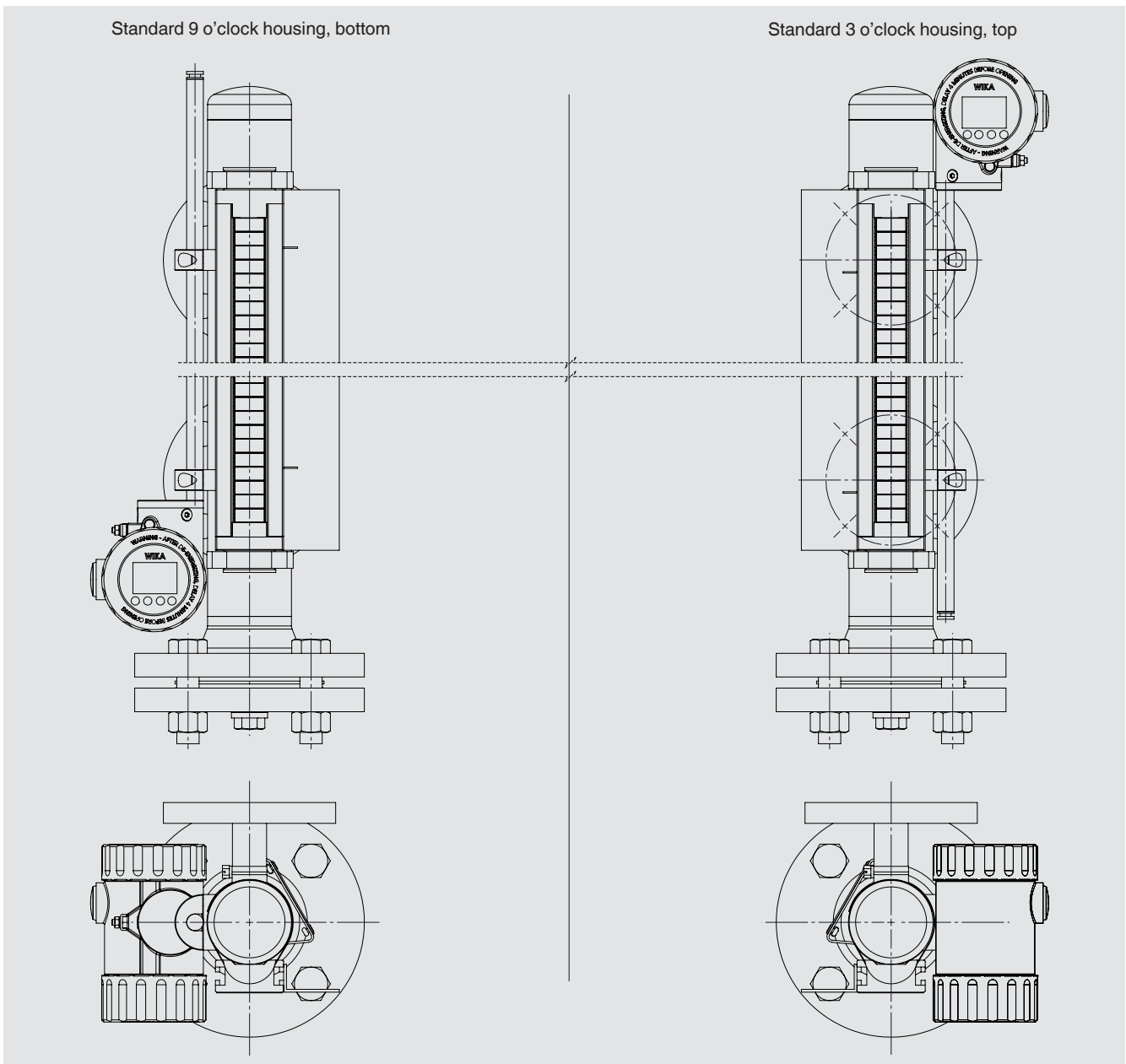

HART® is a registered trademark of HART® Communication Foundation.

### Ordering information

Model / Version / Electrical connection / Process connection / Guide tube diameter / Guide tube length L / 100 % mark L1 / Measuring range M (span 0 ... 100 %) / Process specifications (operating temperature and pressure, limit density) / Options

© 12/2024 WIKA Alexander Wiegand SE & Co. KG, all rights reserved.  
The specifications given in this document represent the state of engineering at the time of publishing.  
We reserve the right to make modifications to the specifications and materials.  
In case of a different interpretation of the translated and the English data sheet, the English wording shall prevail.

